

EE 121-1

S-DIAS Energy Measuring Module

Instruction Manual

Publisher: SIGMATEK GmbH & Co KG
A-5112 Lamprechtshausen
Tel.: +43/6274/4321
Fax: +43/6274/4321-18
Email: office@sigmatek.at
WWW.SIGMATEK-AUTOMATION.COM

Copyright © 2023
SIGMATEK GmbH & Co KG

Translation of Original Instructions

All rights reserved. No part of this work may be reproduced, edited using an electronic system, duplicated, or distributed in any form (print, photocopy, microfilm, or in any other process) without express permission.

We reserve the right to make changes in the content without notice. SIGMATEK GmbH & Co KG is not responsible for technical or printing errors in this handbook and assumes no responsibility for damages that occur through its use.

S-DIAS Energy Measuring Module

EE 121-1

The S-DIAS energy measuring module is used to record power and energy, as well as power synchronization. The voltages from the three input phases (L1, L2 and L3) are measured, as well as the mains frequency and timestamp of the zero-voltage crossings. Additionally, up to 12 currents are also recorded. The currents can be arbitrarily assigned to the phases.

The voltages are connected directly, the currents however, must be connected through the output of a current transformer with 1 A rms output.



Table of Contents

1	S-DIAS Energy Measuring Module Functionality	5
1.1	General Calculations	5
1.2	Event-Triggered Calculations.....	5
1.3	Osc	6
2	Introduction.....	7
3	Basic Safety Guidelines	8
3.1	Symbols Used	8
3.2	Disclaimer	9
3.3	General Safety Guidelines	10
3.4	Software/Training	11
4	Norms and Guidelines.....	12
4.1	Guidelines.....	12
4.1.1	EU Conformity Declaration	12
5	Technical Data	13
5.1	Voltage Input Specifications.....	13
5.2	Current Input Specifications.....	14
5.3	Electrical Requirements.....	15
5.4	Miscellaneous	17
5.5	Environmental Conditions	17
6	Mechanical Dimensions	18

7	Connector Layout	19
7.1	Status LEDs.....	20
7.2	Applicable Connectors.....	20
7.3	Label Field	22
8	Wiring	23
8.1	Example Connection 3-Phase Load with N.....	23
8.2	Example Connection 3-Phase Load with N.....	24
8.3	Example Connection 1-Phase Load with N.....	25
8.4	Notes	26
9	Considerations when Selecting the Current Transformer/Connection	27
9.1	Error Curve of Low-Voltage Current Transformers.....	28
9.2	Short-Circuit Current Converter	29
9.3	Description of the Current transformer Terminals.....	29
9.4	Current Converter UL Requirements	29
10	Transport/Storage	30
11	Mounting	31
12	Address Mapping Energy Measurement	33
12.1	Address Mapping Standard	33
12.2	OSC Channel Setup	38
12.3	Address Mapping 2.....	41

13	Maintenance	49
15	Hardware Class EE121	50
15.1	General.....	52
15.2	Module-Specific	53
15.3	Internal Properties	54
15.3.1	Using the Trigger Function	54
15.4	Global Methods	55
15.4.1	OsciGetStreamingData.....	55
15.4.2	GetHWTimeStamp	55

1 S-DIAS Energy Measuring Module Functionality

1.1 General Calculations

- Current inputs can be enabled/disabled
- Current inputs can be assigned to any voltage input
- monitoring the voltages (star voltage $Lx - N$ or phase conductor voltage $Lx - Ly$)
- Current monitor
- Voltage phase sequence monitor
Monitoring the phase position (P of each configured channel must be positive / monitoring can be enabled/disabled through the application)
- Frequency monitor (min/max/actual // min and max can be set to actual on command)
- Calculation of U_{eff} and I_{eff} of each channel
- Detection of short power interruptions (threshold value to U_{eff})
- Indicate 0-crossing for the application (e.g. for synchronized phase measurements, as with monitoring heating currents)
- Energy usage since the initial activation (null voltage proof) [kWh]
- Energy usage can be reset (null voltage proof) [kWh]
- Total value: P and $\cos(\varphi)$ with ohmic/inductive and ohmic/capacitive load
- Indication of whether the load is capacitive or inductive
- For mains synchronization applications, a timestamp function to the zero-voltage crossing is provided. This function determines the time offset of zero-voltage crossings of 2 voltage supplies when using multiple energy measuring modules.

1.2 Event-Triggered Calculations

The evaluation time windows can be set as desired with the Cycle Run and Cycle Start bits.

The following functions can be analyzed over all channels:

- $\cos(\varphi)$ with ohmic/inductive or ohmic/capacitive load
- Energy use [Ws]
- Energy use per shot weight [Ws/g]
- Maximum power [W]

The following functions can be analyzed over every voltage channel :

- U_{eff} [V]

The following functions can be analyzed over every current channel:

- $\cos(\varphi)$ with ohmic/inductive and ohmic/capacitive load
- I_{eff} [A]
- Power [W]
- I_{Peak} [A]

1.3 Osc

The oscilloscope function is implemented for 4 selectable channels/parameters with a variable time base.

Trigger functions:

- Positive edge
- Negative edge
- Force Trigger
- Buffer full

2 Introduction

2.1 Target Group/Purpose of this Manual

This operating manual contains all information required to operate this product.

This operating manual is intended for:

- Project planners
- Technicians
- Commissioning engineers
- Machine operators
- Maintenance/test technicians

General knowledge of automation technology is required.

Further help and information on training, and the appropriate accessories can be found on our website www.sigmatek-automation.com.

Our support team is happily available to answer your questions.
Please see our website for our hotline number and business hours.

2.2 Contents of Delivery

1x EE 121-1

1x opposing connector

3 Basic Safety Guidelines

3.1 Symbols Used

The following symbols are used in the operator documentation for warning and danger messages, as well as informational notes:

DANGER



Danger indicates that death or serious injury **will** occur, if the specified measures are not taken.

⇒ To avoid death or serious injuries, observe all guidelines.

Danger indique une situation dangereuse qui, faute de prendre les mesures adéquates, entraînera des blessures graves, voire mortelles.

⇒ Respectez toutes les consignes pour éviter des blessures graves, voire mortelles.

WARNING



Warning indicates that death or serious injury **can** occur, if the specified measures are not taken.

⇒ To avoid death or serious injuries, observe all guidelines.

Avertissement d'une situation dangereuse qui, faute de prendre les mesures adéquates, entraînera des blessures graves, voire mortelles.

⇒ Respectez toutes les consignes pour éviter des blessures graves, voire mortelles.

CAUTION



Caution indicates that moderate to slight injury **can** occur, if the specified measures are not taken.

⇒ To avoid moderate to slight injuries, observe all guidelines.

Attention indique une situation dangereuse qui, faute de prendre les mesures adéquates, peut entraîner des blessures assez graves ou légères.

⇒ Respectez toutes les consignes pour éviter des blessures graves, voire mortelles.



Information

Provides important information on the product, handling or relevant sections of the documentation, which require particular attention.

Fournit des recommandations importantes sur le produit, la manipulation ou sections pertinentes de la documentation, qui nécessitent prêter une attention particulière.



Warning, dangerous electrical voltage



Danger for ESD-sensitive components.

3.2 Disclaimer



The contents of this operating manual were prepared with the greatest care. However, deviations cannot be ruled out. This operating manual is regularly checked and required corrections are included in the subsequent versions. The machine manufacturer is responsible for proper installation, as well as device configuration. The machine operator is responsible for safe handling, as well as proper operation.

The current operating manual can be found on our website. If necessary, contact our support.

Subject to technical changes, which improve the performance of the devices. The following operating manual is purely a product description. It does not guarantee properties under the warranty.

Please thoroughly read the corresponding documentation and this operating manual before handling a product.

SIGMATEK GmbH & Co KG is not liable for damages caused through non-compliance with these instructions or applicable regulations.

3.3 General Safety Guidelines

The safety guidelines in the other sections of this operating manual must be observed. These instructions are visually emphasized by symbols.



According to EU Guidelines, the operating instructions are a component of a product.

This operating manual must therefore be accessible in the vicinity of the machine since it contains important instructions.

This operating manual should be included in the sale, rental or transfer of the product, or its online availability indicated.

Maintain this operating manual in readable condition and keep it accessible for reference.

Regarding the requirements for Safety and health connected to the use of machines, the manufacturer must perform a risk assessment in accordance with machine guidelines 2006/42/EG before introducing a machine to the market.

Before commissioning this product, check that conformance with the provisions of the 2006/42/EG guidelines is correct. As long as the machine with which the with the device should be used does not comply with the guideline, operating this product is prohibited.

Operate the unit with devices and accessories approved by SIGMATEK only.

CAUTION



Handle the device with care and do not drop or let fall.

Prevent foreign bodies and fluids from entering the device.

The device must not be opened, otherwise it could be damaged!

The module complies with EN 61131-2.

In combination with a machine, the machine builder must comply with EN 60204-1 standards.

For your own safety and that of others, compliance with the environmental conditions is essential.

The control cabinet must be connected to ground correctly.

To perform maintenance or repairs, disconnect the system from the power supply.

3.4 Software/Training

The application is created with the software LASAL CLASS 2 and LASAL SCREEN Editor.

Training for the LASAL development environment, with which the product can be configured, is provided. Information on our training schedule can be found on our website.

4 Norms and Guidelines

4.1 Guidelines

The product was constructed in compliance with the following European Union guidelines and tested for conformity.

4.1.1 EU Conformity Declaration



EU Conformity Declaration

The EE 121-1 conforms to the following European guidelines:

- **2014/35/EC** Low Voltage Directive
- **2014/30/EU** “Electromagnetic Compatibility” (EMC guideline)
- **2011/65/EU** “Restricted use of certain hazardous substances in electrical and electronic equipment” (RoHS Guideline)

The EU Conformity Declarations are provided on the SIGMATEK website. See Products/Downloads or use the search function and the keyword “EU Declaration of Conformity”.

5 Technical Data

5.1 Voltage Input Specifications

Number of channels	3
Supported nominal system voltage	0-480 V AC (phase conductor voltage Lx – Ly) 0-277 V AC (star voltage Lx - N / Lx - PE)
Measurement range	0-520 V AC (phase conductor voltage Lx – Ly) 0-300 V AC (star voltage Lx - N / Lx - PE)
Measurement value	0-52,000 (10 mV/d) 0-30,000 (10 mV/d)
frequency range	15-120 Hz
ADC resolution	16-bit (ca. 25 mV/LSB)
Scan rate	15 μ s
Voltage inputs frequency measurement range	15-120 Hz with a 0.01 Hz resolution
Frequency measurement accuracy	typically 10 mHz at 400 V AC/50 Hz and sine-formed mains voltage
Zero-voltage crossing timestamp	0 to (32767 - bus cycle time) in 1 μ s increments
Input filter hardware	1.5 kHz
Galvanic separation (voltage inputs to S-DIAS bus)	4000 V AC (1 min)
Base accuracy incl. calibration errors, linearity and noise at 25 °C	± 0.25 % based on the auf die nominal system voltage of 480 V AC (Lx - Ly)/277 V AC (Lx - N / Lx - PE) within the nominal system voltage range at a mains frequency of 45 to 65 Hz
Temperature drift 0-60 °C	± 0.35 % based on the auf die nominal system voltage of 480 V AC (Lx - Ly)/277 V AC (Lx - N / Lx - PE) within the nominal system voltage range at a mains frequency of 45 to 65 Hz
Total accuracy (0-60 °C)	± 0.60 % based on the auf die nominal system voltage of 480 V AC (Lx - Ly)/277 V AC (Lx - N / Lx - PE) within the nominal system voltage range at a mains frequency of 45 to 65 Hz



The EE 121-1 does not filter the ripple control signals, which range from 110 Hz to 2 kHz, sent from the power company. These signals can affect the frequency measurement and timestamp of the zero-voltage crossings. For mains synchronization applications, the end user must take the appropriate filtering measures when required.

5.2 Current Input Specifications

Number of channels	12
Supported current converters, secondary nominal current	1 A AC
Measurement range	0-2 A AC ¹⁾
Measurement value	0-20,000 x I _{Primary} /I _{Secondary} (0.1 mA/d)
Permissible overcurrent	2 A continuous ¹⁾ 5 A for 20 s 10 A for 1 s
frequency range	15-120 Hz
ADC resolution	16 Bit (ca. 50 μ A/LSB)
Scan rate	30 μ s
Current shunt	60 M Ω
Input filter hardware	1.5 kHz
Galvanic separation (current inputs to S-DIAS bus)	none
Base accuracy incl. calibration errors, linearity and noise at 25 °C	± 0.25 % based on the auf die nominal current of 1 A within the nominal current range of 1 A AC at a mains frequency of 45 to 65 Hz
Temperature drift 0-60 °C	± 0.40 % based on the auf die nominal current of 1 A within the nominal current range of 1 A AC at a mains frequency of 45 to 65 Hz
Total accuracy (0-60 °C)	± 0.65 % based on the auf die nominal current of 1 A within the nominal current range of 1 A AC at a mains frequency of 45 to 65 Hz

¹⁾ Only 50% of channels 1-6 and 50% of channels 7-12 can be loaded with a maximum of 2 A at the same time.

The current inputs must be connected to the current transformer.

5.3 Electrical Requirements

Voltage supply from S-DIAS bus	+5 V	
Current consumption on the S-DIAS bus (+5 V supply)	0	
Power supply on the S-Dias bus	+24 V (+18 V to +30 V)	
Current consumption on the S-DIAS bus (+24 V supply)	typically 45 mA	maximum 60 mA



If this S-DIAS module is connected to an S-DIAS supply module with several S-DIAS modules, the total current of the modules used must be determined and checked.

The total current of the +24 V supply cannot exceed 1.6 A.

The total current of the +5 V supply cannot exceed 1.6 A.

The specification for the current can be found in the module-specific documentation under "Electrical Requirements".

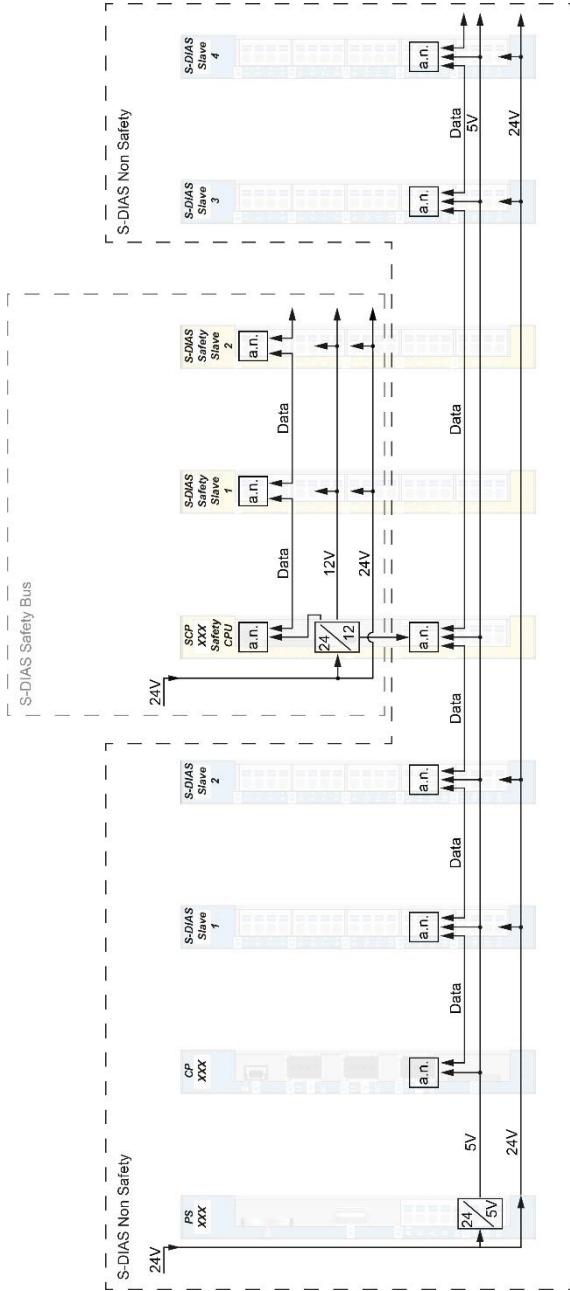

Wiring S-DIAS Safety in S-DIAS System

a.n. = active node

- each S-DIAS module is an active module (active node)
- Safety CPU is connected to the S-DIAS bus (incl. +5V supply)
- Safety bus is independent and separated from the S-DIAS bus

5.4 Miscellaneous

Article number	20-068-121-1
Standard	UL 61010-1, CAN/CSA-C22.2
Approvals	CE, UL

5.5 Environmental Conditions

Storage temperature	-20 ... +85°C	
Ambient temperature	0 ... +60°C	
Humidity	0-95 %, non-condensing	
Installation altitude above sea level	0-2000 m without derating > 2000 m with derating of the maximum environmental temperature by 0.5 °C per 100 m	
Operating conditions	Over voltage category II, up to 5000 m Over voltage category III, up to 2000 m pollution degree 2	
EMC resistance	according to EN 61000-6-2 (industrial area)	
EMC noise generation	according to EN 61000-6-4 (industrial area)	
Vibration resistance	EN 60068-2-6	3.5 mm from 5-8.4 Hz 1 g from 8.4-150 Hz
Shock resistance	EN 60068-2-27	15 g
Protection type	EN 60529	IP20 ¹⁾

¹⁾ Not evaluated by UL

6 Mechanical Dimensions

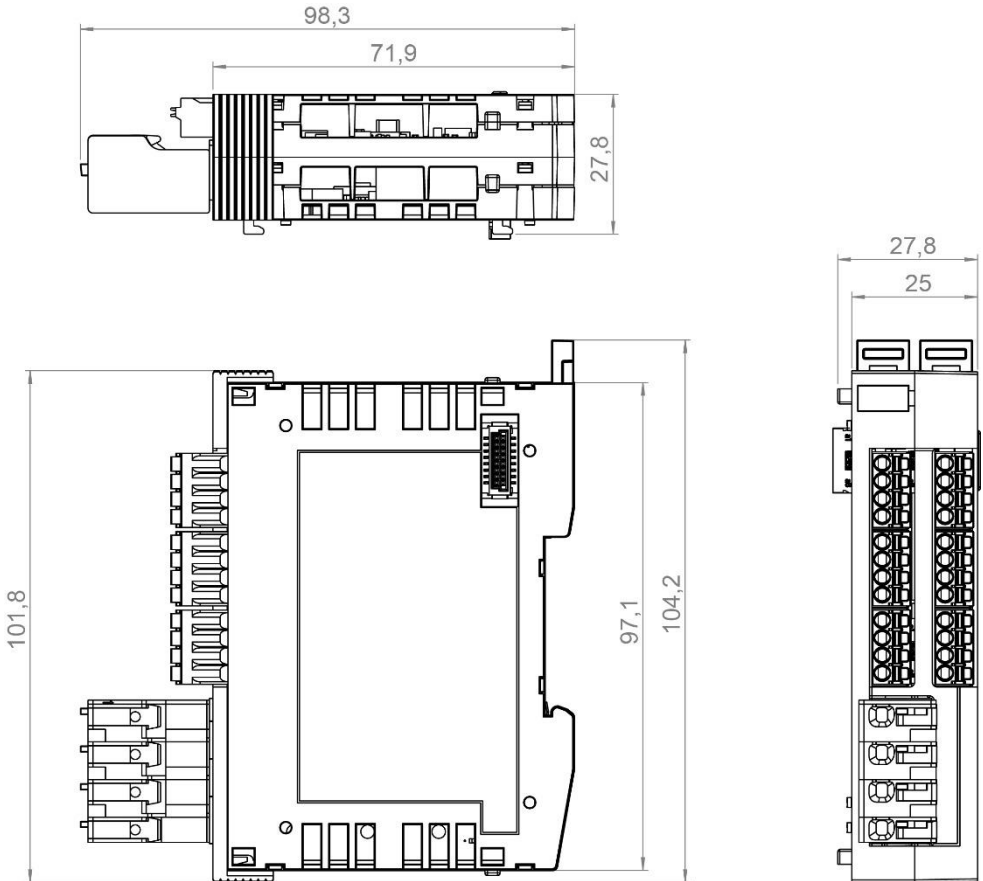

7 Connector Layout

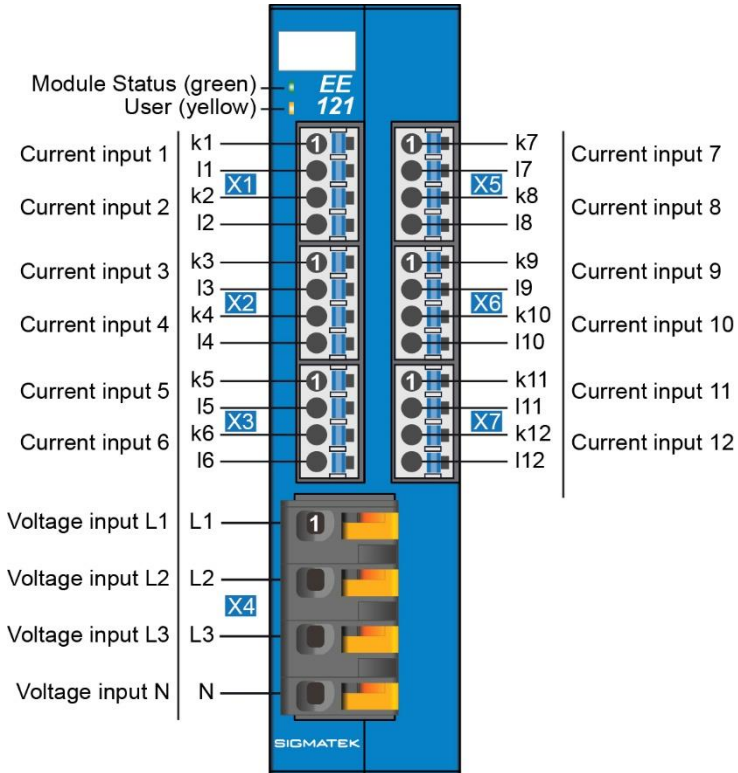

7.1 Status LEDs

Module Status	green	ON	module active
		OFF	no supply available
		BLINKING (5 Hz)	no communication
User	yellow	ON	can be set from the application
		OFF	(e.g. the module LED can be set to blinking through the visualization, so that it is easily found in the control cabinet)
		BLINKING (2 Hz)	
		BLINKING (4 Hz)	

7.2 Applicable Connectors

Current Connector Plugs:

X1-X3, X5-X7: Connectors with spring terminals (included with delivery)

The spring terminals are suitable for the connection of ultrasonically compressed (ultrasonically welded) strands.

Connections:

Stripping length/sleeve length:	10 mm
Mating direction:	parallel to the conductor axis or circuit board
Conductor cross-section rigid:	0.2-1.5 mm ²
Conductor cross section flexible:	0.2-1.5 mm ²
Conductor cross-section strands ultrasonically compacted:	0.2-1.5 mm ²
Conductor cross-section AWG/kcmil:	24-16
Conductor cross-section flexible with ferrule without plastic sleeve:	0.25-1.5 mm ²
Conductor cross-section flexible with ferrule with plastic sleeve:	0.25-0.75 mm ² (reason for reduction d2 of the ferrule)



Cable material: Copper

AWG24-16

Temperature rating of the cable: minimum 75 °C

Voltage Connector plugs:

X4: Connectors with spring terminals (included with delivery)

The spring terminals are suitable for the connection of ultrasonically compressed (ultrasonically welded) strands.

Connections:

Stripping length/sleeve length:	10 mm
Mating direction:	parallel to the conductor axis or circuit board
Conductor cross-section rigid:	0.5-2.5 mm ²
Conductor cross-section flexible:	0.5-4 mm ²
Conductor cross-section strands ultrasonically compacted:	0.5-2.5 mm ²
Conductor cross-section AWG/kcmil:	20 to +12
Conductor cross-section flexible with ferrule without plastic sleeve:	0.34-2.5 mm ²
Conductor cross-section flexible with ferrule with plastic sleeve:	0.34-2.5 mm ²

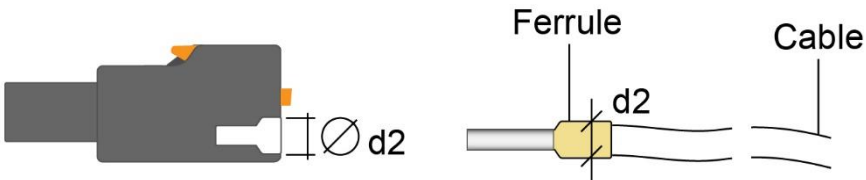

d2 = max. 4.0 mm



The S-DIAS module CANNOT be connected/disconnected while voltage is applied!

Cable material: Copper

AWG20-12

Temperature rating of the cable: minimum 80 °C

7.3 Label Field

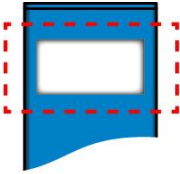

Manufacturer	Weidmüller
Type	MF 10/5 CABUR MC NE WS
Article number Weidmüller	1854510000
Compatible printer	Weidmüller
Type	Printjet Advanced 230V
Article number Weidmüller	1324380000

8 Wiring

8.1 Example Connection 3-Phase Load with N

Wiring example for measuring the energy consumption of a 3-phase load with neutral line

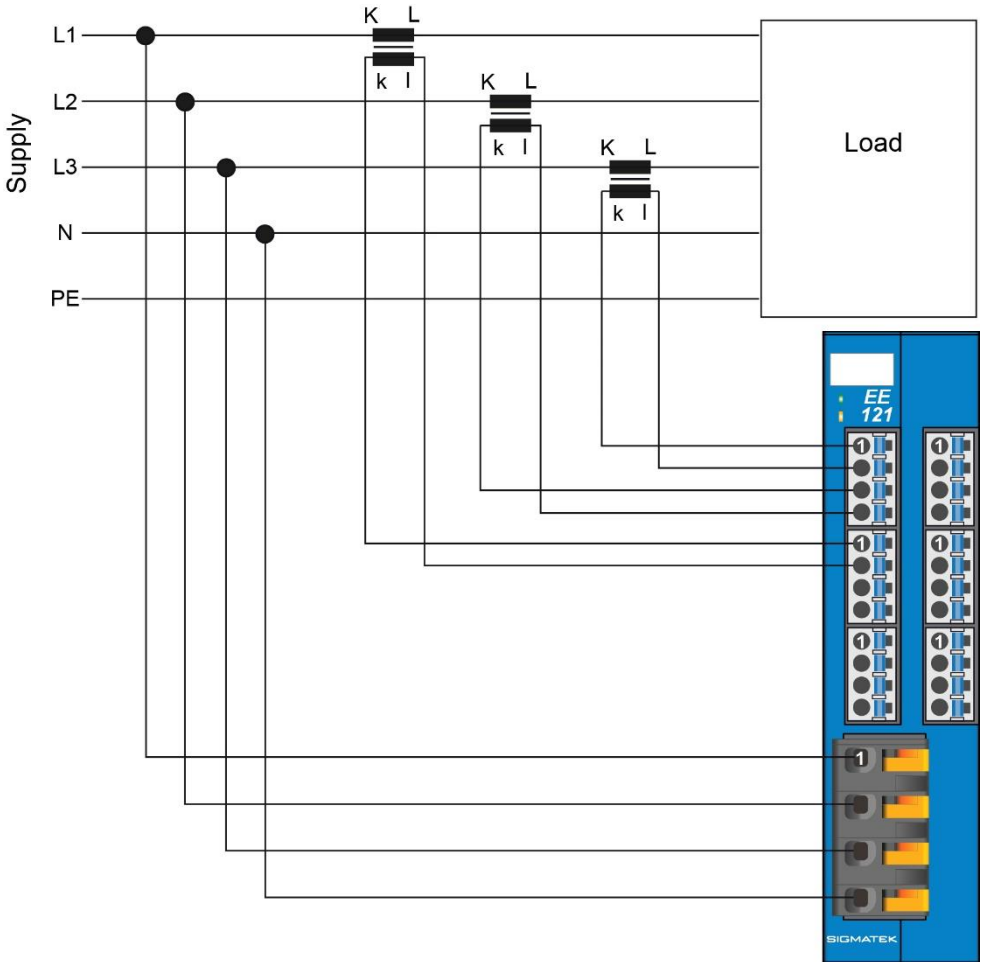

8.2 Example Connection 3-Phase Load with N

Wiring example for measuring the energy consumption of a 3-phase load without neutral line

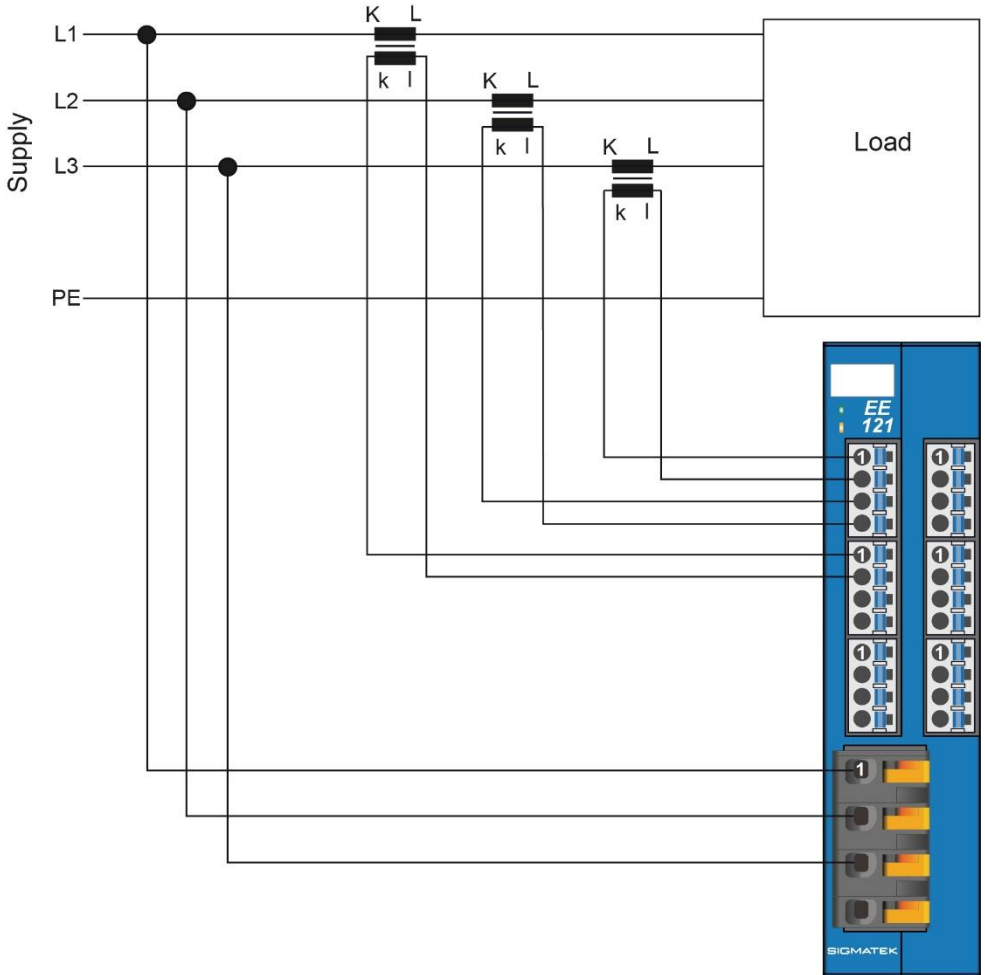

8.3 Example Connection 1-Phase Load with N

Energy measurement of a 1-phase load

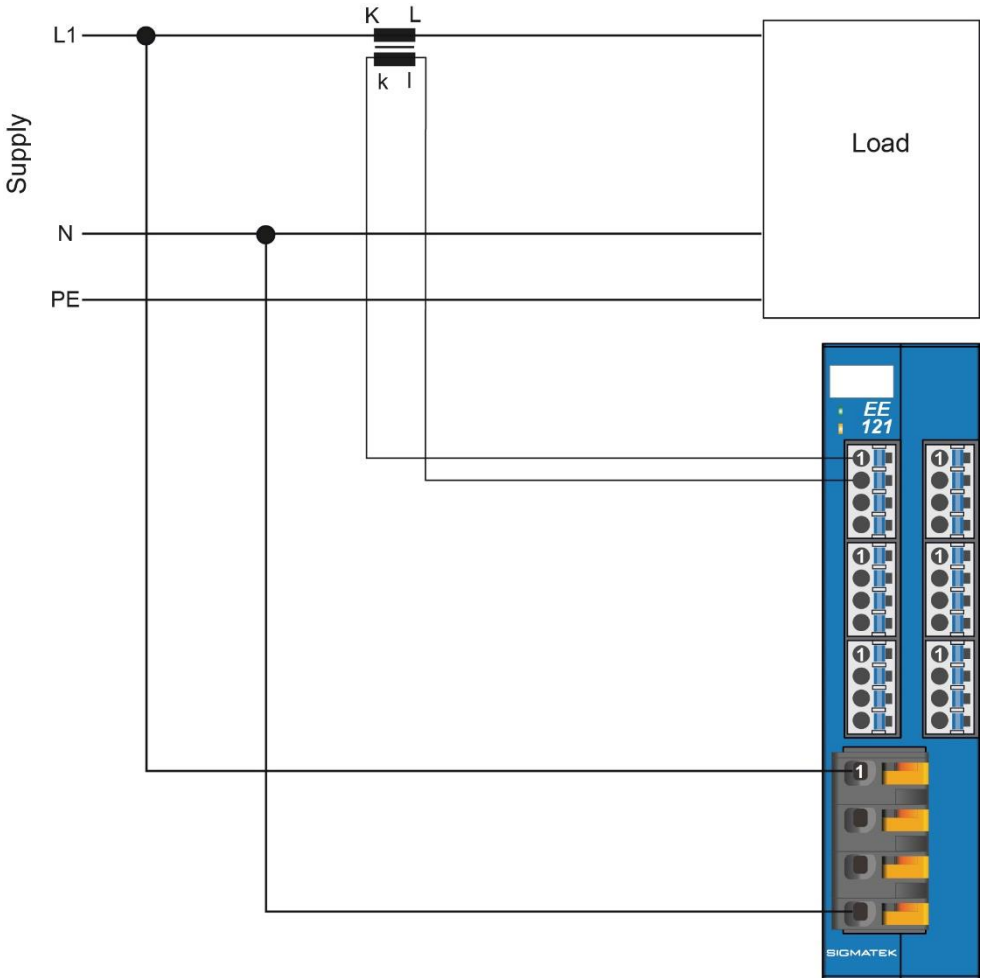

8.4 Notes

The input filters, which suppress noise signals, allow operation in harsh environmental conditions. A careful wiring method is also recommended to ensure error-free function.

- The DIN rail must have an adequate connection to mass.
- The lines connected to the current converters must be as short as possible and parallel wiring to digital signal lines must be avoided.
- Shielded wires are recommended for connection lines to the current converter.
- The shielding must be connected to a shielding bus.
- Avoid parallel connections between input lines and load-bearing circuits.
- Protective circuits for all relays (RC networks or free-wheeling diodes).



The ground bus should be connected to the control cabinet when possible!

9 Considerations when Selecting the Current Transformer/Connection

In IEC600044-1, the precision of the current transformer is defined in the range of 25% to 120% of the nominal load. If the current transformer has less than 25% of the nominal load, the maximum allowed error can be exceeded.

With an additional ohmic load (resistor in series), the measurement precision can be improved.

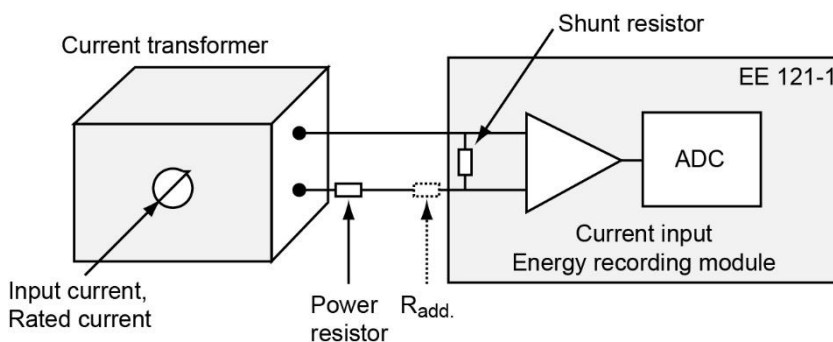

Shunt resistance = 0.06 Ω

Nominal load at ideal nominal current = circuit resistance + shunt resistance (+ possible R_{add})

Example:

Current transformer with:

Secondary nominal current = 1 A rms

Maximum rated power = 1 VA

Nominal load = 1 Ω (0.06 Ω Shunt + 0.94 Ω line)

$$\text{Nominal load} = \frac{\text{rated power}}{\text{Secondary current}^2} + \frac{1 \text{ VA}}{1 \text{ A}^2} = 1 \Omega$$

$$\text{Line resistance} = \frac{2 \times \text{wire length in m (feed and return line)}}{56 \times \text{wire diameter in mm}^2 \text{ (copper)}}$$

$R_{\text{additional resistance}} = \text{nominal load} - \text{line resistance} - \text{shunt resistance}$

$$P_{\text{additional resistance}} = I_n^2 * R_{\text{additional resistance}}$$

9.1 Error Curve of Low-Voltage Current Transformers

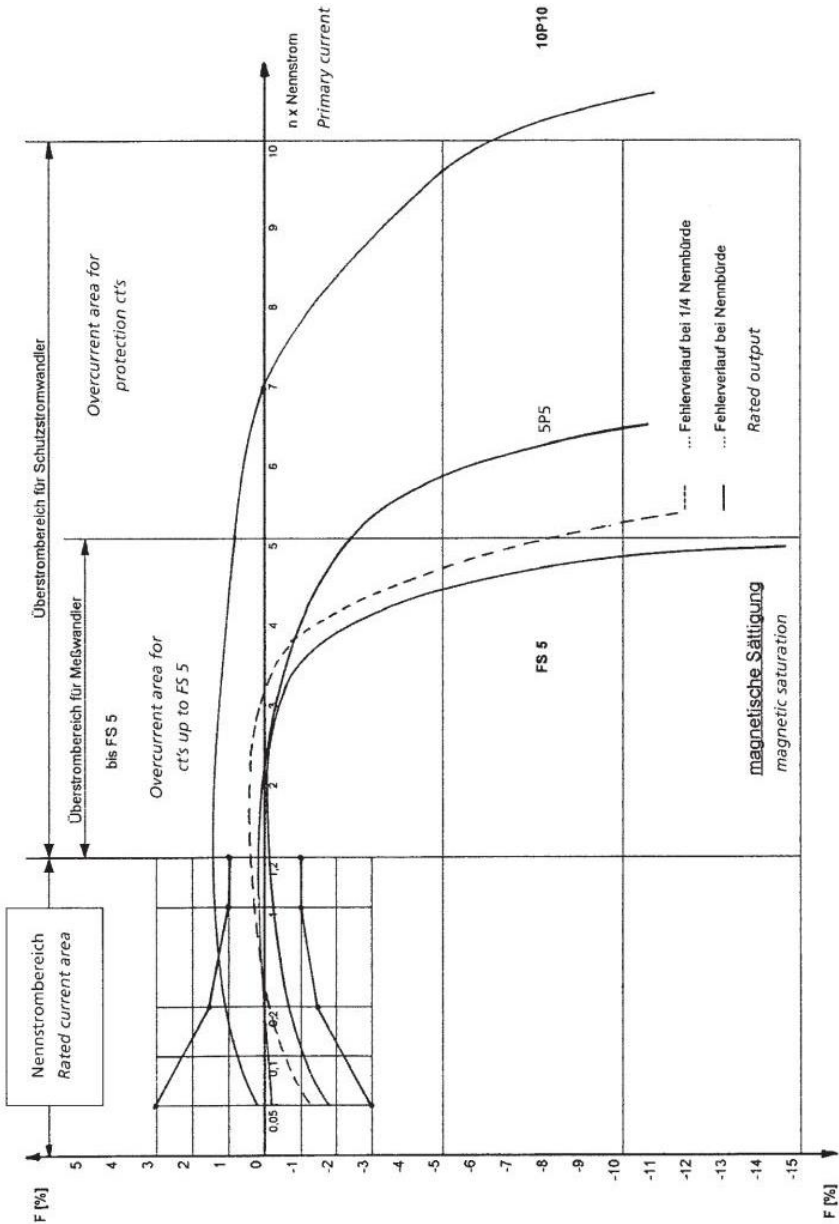

9.2 Short-Circuit Current Converter

An FS5 converter is recommended, which limits the secondary short-circuit current to 5 times the secondary nominal current when connected with a nominal load. A secondary nominal current of 1 A is therewith ensured, which with a primary-side short circuit, the secondary short-circuit current does not exceed 5 A. The module is temporarily overload proof. The short-circuit current must be turned off, at the latest, after 20 seconds to protect the module from damage.

9.3 Description of the Current transformer Terminals

The terminals for all primary windings are labeled with "K-P1" and "L-P2", the terminals for all secondary windings are labeled with the corresponding lower case letters "k-s1" and "l-s2"

For current transformers with several secondary leads, the winding end "l" is then assigned an extra digit "l1", the leads are sequentially assigned the numbers "2", "3", etc. as the number of turns reduce.

For summation current transformers, with several independent primary windings, the individual windings before those identified with the capital letters "K" and "L" must be labeled with the capital letters "A", "B", "C", etc

For example "AK" - "AL" for the highest primary circuit, "BK" - "BL" for the second primary circuit etc.; or the transformation or transformation ratio of the individual primary windings to one another must be specified for each terminal pair.

9.4 Current Converter UL Requirements

- Current converter listed under UL Product Category XOBA/7
- Current converter voltage rating: minimum 300 V AC
- Current converter overvoltage category (required category depends on application)
 - minimum OVC II (up to 5000 m) or
 - minimum OVC III (up to 2000 m)

10 Transport/Storage



This device contains sensitive electronics. During transport and storage, high mechanical stress must therefore be avoided.

For storage and transport, the same values for humidity and vibration as for operation must be maintained!

During transport, temperature and humidity fluctuations may occur. Ensure that no moisture condenses within or on the device.

11 Mounting

The S-DIAS modules are designed for installation into the control cabinet. To mount the modules, a DIN-rail is required. The DIN rail must establish a conductive connection with the back wall of the control cabinet. The individual S-DIAS modules are mounted on the DIN rail as a block and secured with latches. The functional ground connection from the module to the DIN rail is made via the grounding lug on the back of the S-DIAS modules. The modules must be mounted horizontally (module label up) with sufficient clearance between the ventilation slots of the S-DIAS module blocks and nearby components and/or the control cabinet wall. This is necessary for optimal cooling and air circulation to ensure proper function up to the maximum operating temperature.

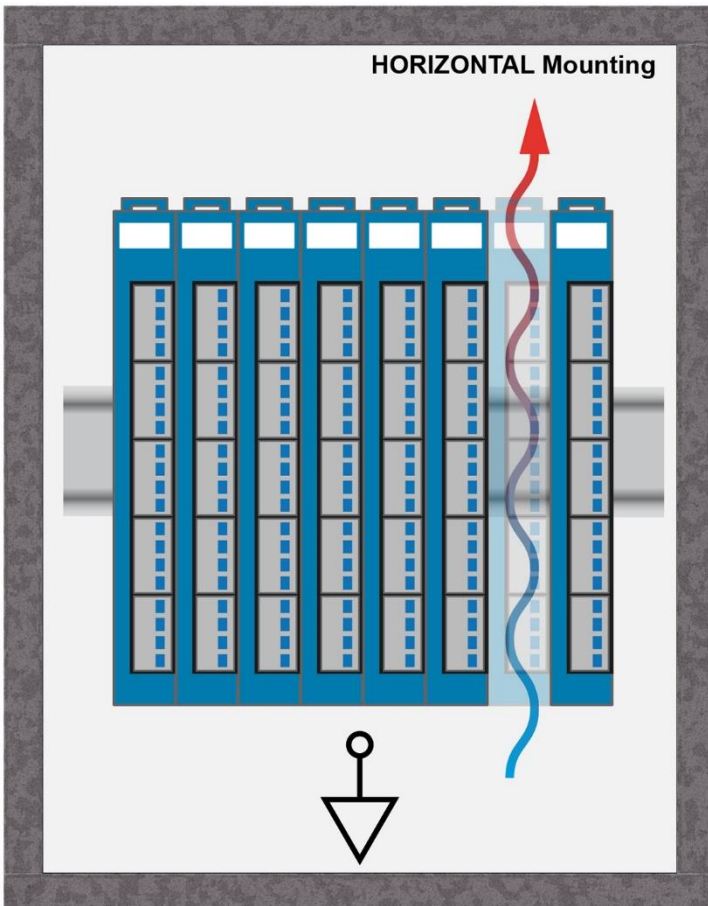

Recommended minimum distances between the S-DIAS modules and the surrounding components or control cabinet wall:

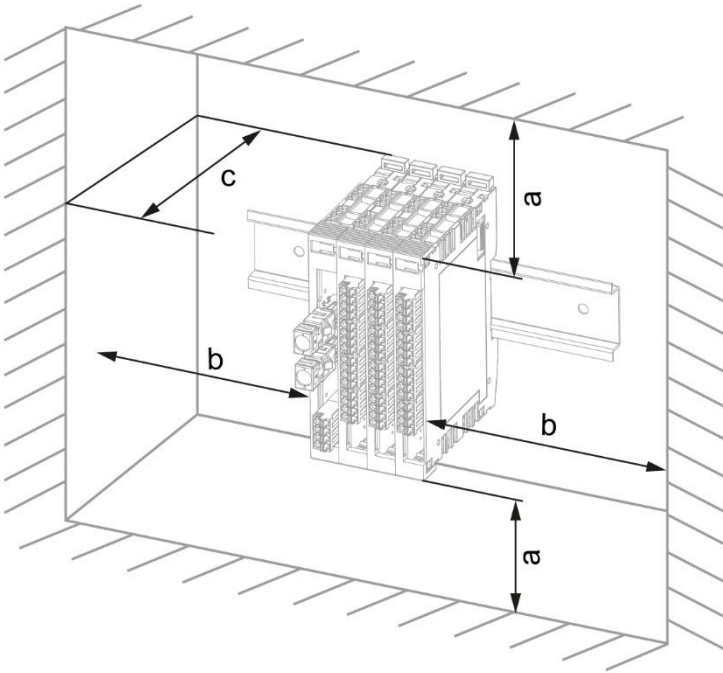

a	b	c
30 mm (1.18")	30 mm (1.18")	100 mm (3.94")

a, b, c ... distances in mm (inches)

12 Address Mapping Energy Measurement

The energy measuring module can be set for 2 operating modes.

In default mode, the following address mapping is applied. If bit 7 is set in offset 0004, the address mapping changes in the range from 0010 to 020F.

Note: The hardware class uses the default mode.

12.1 Address Mapping Standard

Address mapping is active after power-on

Address (hex)	Size (bytes)	Access Type	Description	Reset value
Control				
0000	2	r/w1s	Reset energy consumption (writing 1 to a bit sets the request, it is deleted by the μ C) Bit 15: Reset energy consumption Bit 14..12: Reserved Bit 11: Reset energy consumption I-Channel 12 ... Bit 1: Reset energy consumption I-Channel 2 Bit 0: Reset energy consumption I-Channel 1	0000
0002	1	r/w1s	Reset frequency Min/Max (writing 1 to a bit sets the request, it is deleted by the μ C) Bit 7..3: reserved Bit 2: Reset Phase 3 Bit 1: Reset Phase 2 Bit 0: Reset Phase 1	00
0003	1	r/w1s	Event Trigger Control Bit 7..2: reserved Bit 1: Cycle Bit 0: Cycle start (writing 1 to the bit sets the request, it is deleted by the μ C)	00
0004	1	r	General settings Bit 7: Address mapping 2 (0=Default, 1=Mapping 2) Bit 6..1: Reserved Bit 0: Compatibility Mode (0 = off, 1 = active)	00
0005	4	r	reserved	
0009	1	r	Zero-point crossing timestamp status Bit 7..3: reserved Bit 2: Timestamp Phase 3 invalid Bit 1: Timestamp Phase 2 invalid Bit 0: Timestamp Phase 1 invalid	00
000A	2	r	Timestamp phase 1 zero-point crossing Bit 15: Edge (1 = rising edge, 0 = falling edge) Bit 14..0: Timestamp in 1 μ s resolution	0000

000C	2	r	Timestamp phase 2 zero-point crossing Bit 15: Edge (1 = rising edge, 0 = falling edge) Bit 14..0: Timestamp in 1 μ s resolution	0000
000E	2	r	Timestamp phase 3 zero-point crossing Bit 15: Edge (1 = rising edge, 0 = falling edge) Bit 14..0: Timestamp in 1 μ s resolution	0000
Total				
0010	4	r	Total status Bit 31..20: Cos(Phi) [0.001] Bit 19..10: reserved Bit 9: Error maintenance data EE (kWh) Bit 8: Error Calibration Data EE Bit 7..1: reserved Bit 0: Error Phase Sequence U	00
0014	4	r	Actual power [0.01 W].	00000000
0018	4	r	Total energy consumption since initial activation [0.1 kWh].	00000000
001C	4	r	Total Energy consumption since the last reset [0.1 kWh]	00000000
Event-triggered calculations				
0020	4	r	Event-triggered status: Bit 31..20: Cos(Phi) [0.001] Bit 19..3: reserved Bit 2: Overflow Error Bit 1: Cycle Bit 0: Cycle Start	000000
0024	4	r	Energy consumption over time range [1 Ws]	00000000
0028	4	r	Maximum power: [0.01 W]	00000000
002C	4	r	Total energy consumption since the last power-up [0.1 Wh]	00000000
Voltage channels (U ₁ at 0030, U ₂ at 003C, U ₃ at 0048)				
0030	2	r	Number of the corresponding status: Bit 15..6: reserved Bit 5: Frequency over range (f > 120 Hz) Bit 4: Frequency under range (f < 15 Hz) Bit 3: Overvoltage (voltage > measurement range) Bit 2: Actual voltage value is positive (0 = negative)(for zero-voltage crossing detection) Bit 1: U _{eff1} warning (voltage below threshold setting) Bit 0: U _{eff1} error (voltage below 50 V)	0000
0032	2	r	U _{eff1} [10 mV]	0000
0034	2	r	U _{eff1} [10 mV] event-triggered	0000
0036	2	r	U ₁ actual frequency [0.01 Hz]	0000
0038	2	r	U ₁ minimum frequency [0.01 Hz]	0000
003A	2	r	U ₁ maximum frequency [0.01 Hz]	0000
003C		r	U ₂ and U ₃	0000
...				

004F				
Voltage channels (U ₁₂ at 0054, U ₂₃ at 0058, U ₃₁ at 005C)				
0054	2	r	U _{eff12} [10 mV]	0000
0056	2	r	U _{eff12} [10 mV] event-triggered	0000
0058	2	r	U _{eff23} [10 mV]	0000
005A	2	r	U _{eff23} [10 mV] event-triggered	0000
005C	2	r	U _{eff31} [10 mV]	0000
005E	2	r	U _{eff31} [10 mV] event-triggered	0000
Current channels (I ₁ at 0060, I ₂ at 0084, I ₃ at 00A8... I ₁₂ at 01EC)				
0060	4	r	Current status: Bit 31..20: Cos(Phi) [0.001] Bit 19..8: Cos(Phi) [0.001] event-triggered Bit 7: Overcurrent (current > measurement range) Bit 6..5: Load type 0 = no information (firmware cannot determine the load type) 1 = capacitive load (current leads voltage) 2 = inductive load (current lags voltage) 3 = purely resistive load Bit 4: U-I phase error (power is positive) Bit 3: Ieff warning (current below 1A) Bit 2..0: Voltage phase selected 0 = Disabled 1 = Phase U ₁ 2 = Phase U ₂ 3 = Phase U ₃ 4 = Phase U ₁₂ 5 = Phase U ₂₃ 6 = Phase U ₃₁	00
0064	4	r	I _{eff} [0.1 mA]	00000000
0068	4	r	Power [0.01 W]	00000000
006C	4	r	Energy use since initial activation [0.1 kWh].	00000000
0070	4	r	Energy consumption since the last reset [0.1 kWh]	00000000
0074	4	r	I _{eff} [0.1 mA] event-triggered	00000000
0078	4	r	Power [0.01 W] event-triggered	00000000
007C	4	r	I _{peak} [0.1 mA] event-triggered	00000000
0080	4	r	Total energy consumption since the last power-up [0.1 Wh]	00000000
0084 ... 020F	r	Channel I ₂ to I ₁₂	00...
Setup Current Channels (I ₁ at 0210, I ₂ at 0214, I ₃ at 0218 ... I ₁₂ at 023C)				

0210	2	r/w	I ₁ setting Bit 15..3: reserved Bit 2..0: Voltage phase selected 0 = Disabled 1 = Phase U ₁ 2 = Phase U ₂ 3 = Phase U ₃ 4 = Phase U ₁₂ 5 = Phase U ₂₃ 6 = Phase U ₃₁	0000
0212	2	r/w	I1 transformer type [0.1 A]	0000
0214 ... 023F	44	r/w	I2 I ₁₂	
Setup U _{eff} Threshold				
0240	2	r/w	Phase U ₁ U _{eff} threshold for warning [10 mV]	0000
0242	2	r/w	Phase U ₂ U _{eff} threshold for warning [10 mV]	0000
0244	2	r/w	Phase U ₃ U _{eff} threshold for warning [10 mV]	0000
0246 ... 024F	10	r/w	reserved	00...
Firmware Version				
0250	2	r	CRC	0000
0252	2	r	Length	0000
0254	2	r	Firmware version	0000
0256	1	r	reserved	00
0257	1	r	reserved	00
0258 ... 025F	8	r/w	reserved	00...00
Osc Setup				
0260	4	r/w	Time base [μs]	0300
0264	4	r/w	Trigger level only necessary on Edge triggering	00000000
0268	2	r/w	Pre-samples [0.1%]	0000
026A	2	r/w	Trigger setting (0 = Sampling mode) Bit 15..5: reserved (must be written with 0) Bit 4: Trigger when buffer full Bit 3: Trigger on positive edge Bit 2: Trigger on negative edge Bit 1..0: Trigger channel (0 to 3)	00

026C	4	r/w	Channel 1 setup	00000000
0270	4	r/w	Channel 2 Setup	00000000
0274	4	r/w	Channel 3 Setup	00000000
0278	4	r/w	Channel 4 Setup	00000000
027C	1	r/w	Trigger mode Bit 31..4: reserve Bit 3..0: Instruction 0 = no command / continue sampling 1 = Force trigger and continue post samples 2 = force trigger and cancel post samples 3 = restart with last Osc-Setup - settings	00
OSCI Status				
0280	2	r	Bit 15..12: OSC Status 0 = Not initialized 1 = Pre-samples 2 = Wait for trigger 3 = post samples 4 = Ready (only in trigger mode) 5 = Sampling 6 = Buffer Overflow (only in sampling mode) Bit 11..0: trigger sample offset in buffer	0000
0282	2	r16	OSCI Sample Values in Buffer Bit 15..14: channel number of the first sample value (0284) Bit 13 - reserved Bit 12..0: number of sample values in the buffer	0000
0284	4	r32	OSCI captured data value channel 1 sample n**	00000000
0288	4	r32	OSCI captured data value channel 2 sample n**	00000000
028C	4	r32	OSCI captured data value channel 3 sample n**	00000000
0290	4	r32	OSCI captured data value channel 4 sample n**	00000000
0294	4	r32	OSCI Captured Data Value Channel 1 Sample n+1**	00000000
0298	4	r32	OSCI Captured Data Value Channel 2 Sample n+1**	00000000
029C	4	r32	OSCI Captured Data Value Channel 3 Sample n+1**	00000000
02A0	4	r32	OSCI Captured Data Value Channel 4 Sample n+1**	00000000
02A4 ... 02FF	92	r32	...	00000000
0300	22	r/w	reserved	0..0
03DC	36	-	Debug interface (access not permitted)	-

***) A possible sign is expanded Attention, unsigned values are also possible.

12.2 OSC Channel Setup

Bit	Size (bits)	Description
31..25	7	reserved
24	1	1 = Activate channel 0 = Deactivate channel
23	1	1 = Fast internal data 0 = interface data
22	1	1 = Average (0 = momentary value)
21..16	6	Channel number
15..13	3	Group 0 = total 1 = Event triggered 2 = Voltage channels 3 = Current channels
12..8	5	Parameter number Total group: 0 = Status 1 = CosPhi 2 = Actual power 3 = total energy use since initial activation 4 = total energy consumption since the last reset Event-triggered group 0 = Status 1 = CosPhi 2 = Energy consumption over set time range 3 = maximum power Voltage channels group: 0 = Status 1 = U_{eff} 2 = U_{eff} event-triggered 3 = Actual frequency 4 = Minimum frequency 5 = maximum frequency Current channels group: 0 = Status 1 = CosPhi 2 = CosPhi event-triggered 3 = I_{eff} 4 = Power 5 = Energy use since initial activation 6 = energy consumption since the last reset 7 = I_{eff} event-triggered 8 = event-triggered current 9 = I_{peak} event-triggered

7..0	8	Data format selection: Bit 7: with sign Bit 6..5: data size 0 = Bit 1 = 1 bytes 2 = 2 bytes 3 = 4 bytes Bit 4..0: Bit-selector (if data size = Bit) Bit 4..0: Bits selector (only if data size = 1 .. 2 bytes) Bit 4: remove low-order bits and shift right Bit 3: or remove high-order bits Bit 2..0: Number of bits to remove
------	---	--

<i>Parameter number (hex)</i>	<i>Description</i>
Fast Internal Signals U (X = 0 for U ₁ , 1 for U ₂ , 2 for U ₃ , 3 for U ₁₂ , ...)	
0x008X40E0	Actual voltage value [10 mV]
Fast internal signals U (X = 0 for I ₁ , 1 for I ₂ ...)	
0x008X60E0	Actual current value [0.1 mA]
Total	
0x00000000	Status: Bit 0: Error phase sequence U
0x000001D4	Cos(Phi) [0.001]
0x000002E0	Actual power [0.01 W].
0x00000360	Total energy consumption since initial activation [0.1 kWh].
0x00000460	Total energy use since the last reset [0.1 kWh].
Event-controlled calculations	
0x00002000	Status : Bit 0: Cycle Start Bit 1: Cycle Bit 2..23: reserved
0x00002001	
0x000021D4	Cos(Phi)
0x00002260	Energy consumption over the defined time range [1 Ws]
0x000023E0	Maximum power
Voltage Channels U (X = 0 for U ₁ , 1 for U ₂ , 2 for U ₃ , 3 for U ₁₂ , ...)	
0x000X4000 0x000X4001 0x000X4002	Voltage status: Bit 0: U _{eff} error (voltage below 50V) Bit 1: U _{eff} Warning (voltage under threshold setting) Bit 2: actual voltage is positive (0 = negative)

	(for zero-crossing detection) Bit 3.. 15: reserved
0x000X4140	U _{eff} [10 mV]
0x000X4240	U _{eff} [10 mV] event-triggered
0x000X4340	Actual frequency [0.01 Hz]
0x000X4440	Minimum frequency [0.01 Hz]
0x000X4540	Maximum frequency [0.01 Hz]
Current channels (XX = 0 for I ₁ , 1 for I ₂ ,...)	
0x000X6002 0x000X6003	Current status: Bit 1..0: Voltage phase selected 0 = Disabled 1 = Phase 1 2 = Phase 2 3 = Phase 3 Bit 2: I _{eff} warning (current below 1 A) Bit 3: U-I phase error (power is positive) Bit 15..4: reserved
0x000X61D4	Cos(Phi) [0.001]
0x000X62CC	Cos(Phi) event-triggered [0.001]
0x000X6360	I _{eff} [0.1 mA]
0x000X64E0	Power [0.01 W]
0x000X6560	Energy use since initial activation [0.1 kWh].
0x000X6660	Energy consumption since the last reset [0.1 kWh]
0x000X6760	I _{eff} [0.1 mA] event-triggered
0x000X68E0	Power [0.01 W] event-triggered
0x000X69E0	I _{peak} (actual not effective) [0.1 mA] event-triggered

12.3 Address Mapping 2

Note: In this

Address (hex)	Size (bytes)	Access type:	Description	Reset value
Control				
0000	2	r/w1s	Reset energy consumption (writing 1 to a bit sets the request, it is deleted by the μ C) Bit 15: Reset energy consumption Bit 14..12: Reserved Bit 11: Reset energy consumption I-Channel 12 ... Bit 1: Reset energy consumption I-Channel 2 Bit 0: Reset energy consumption I-Channel 1	0000
0002	1	r/w1s	Reset frequency Min/Max (writing 1 to a bit sets the request, it is deleted by the μ C) Bit 7..3: reserved Bit 2: Reset Phase 3 Bit 1: Reset Phase 2 Bit 0: Reset Phase 1	00
0003	1	r/w1s	Event Trigger Control Bit 7..2: reserved Bit 1: Cycle Bit 0: Cycle start (writing 1 to the bit sets the request, it is deleted by the μ C)	00
0004	1	r/w	General settings Bit 7: Address mapping 2 (0=Default, 1=Mapping 2) Bit 6..1: Reserved Bit 0: Compatibility Mode (0 = off, 1 = active)	00
0005	4	r	reserved	
0009	1	r	Zero-point crossing timestamp status Bit 7..3: reserved Bit 2: Timestamp Phase 3 invalid Bit 1: Timestamp Phase 2 invalid Bit 0: Timestamp Phase 1 invalid	00
000A	2	r	Timestamp phase 1 zero-point crossing Bit 15: Edge (1 = rising edge, 0 = falling edge) Bit 14..0: Timestamp in 1 μ s resolution	0000
000C	2	r	Timestamp phase 2 zero-point crossing Bit 15: Edge (1 = rising edge, 0 = falling edge) Bit 14..0: Timestamp in 1 μ s resolution	0000
000E	2	r	Timestamp phase 3 zero-point crossing Bit 15: Edge (1 = rising edge, 0 = falling edge) Bit 14..0: Timestamp in 1 μ s resolution	0000
PDO				

0010	4	r	Total status Bit 31..20: Cos(Phi) [0.001] Bit 19..10: reserved Bit 9: Error maintenance data EE (kWh) Bit 8: Error Calibration Data EE Bit 7..1: reserved Bit 0: Error Phase Sequence U	00
0014	4	r	Actual power [0.01 W].	00000000
Voltage channels (U ₁ at 0018/001E, U ₂ at 001A/0020, U ₃ at 001C/0022)				
0018	2	r	Status U ₁ : Bit 15..6: reserved Bit 5: Frequency over range (f > 120 Hz) Bit 4: Frequency under range (f < 15 Hz) Bit 3: Overvoltage (voltage > measurement range) Bit 2: Actual voltage value is positive (0 = negative)(for zero-voltage crossing detection) Bit 1: Ueff ₁ warning (voltage below threshold setting) Bit 0: Ueff ₁ error (voltage below 50 V)	0000
001A	2	r	Status U ₂ : Bit 15..6: reserved Bit 5: Frequency over range (f > 120 Hz) Bit 4: Frequency under range (f < 15 Hz) Bit 3: Overvoltage (voltage > measurement range) Bit 2: Actual voltage value is positive (0 = negative)(for zero-voltage crossing detection) Bit 1: Ueff ₂ warning (voltage below threshold setting) Bit 0: Ueff ₂ error (voltage below 50 V)	0000
001C	2	r	Status U ₃ : Bit 15..6: reserved Bit 5: Frequency over range (f > 120 Hz) Bit 4: Frequency under range (f < 15 Hz) Bit 3: Overvoltage (voltage > measurement range) Bit 2: Actual voltage value is positive (0 = negative)(for zero-voltage crossing detection) Bit 1: Ueff ₃ warning (voltage below threshold setting) Bit 0: Ueff ₃ error (voltage below 50 V)	0000
001E	2	r	Ueff ₁ [10 mV]	0000
0020	2	r	Ueff ₂ [10 mV]	0000
0022	2	r	Ueff ₃ [10 mV]	0000
0024	2	r	Ueff ₁₂ [10 mV]	0000
0026	2	r	Ueff ₂₃ [10 mV]	0000
0028	2	r	Ueff ₃₁ [10 mV]	0000
002A	2	r	reserved	0000
First Device				
002C	4	r	Status I ₁ : Bit 31..20: Cos(Phi) [0.001] Bit 19..8: Cos(Phi) [0.001] event-triggered Bit 7: Overcurrent (current > measurement range) Bit 6..5: Load type 0 = no information (firmware cannot determine the load)	00

			type) 1 = capacitive load (current leads voltage) 2 = inductive load (current lags voltage) 3 = purely resistive load Bit 4: U-I phase error (power is positive) Bit 3: Ieff warning (current below 1A) Bit 2..0: Voltage phase selected 0 = Disabled 1 = Phase U ₁ 2 = Phase U ₂ 3 = Phase U ₃ 4 = Phase U ₁₂ 5 = Phase U ₂₃ 6 = Phase U ₃₁	
0030	4	r	Status I ₂ : Bit 31..20: Cos(Phi) [0.001] Bit 19..8: Cos(Phi) [0.001] event-triggered Bit 7: Overcurrent (current > measurement range) Bit 6..5: Load type 0 = no information (firmware cannot determine the load type) 1 = capacitive load (current leads voltage) 2 = inductive load (current lags voltage) 3 = purely resistive load Bit 4: U-I phase error (power is positive) Bit 3: Ieff warning (current below 1A) Bit 2..0: Voltage phase selected 0 = Disabled 1 = Phase U ₁ 2 = Phase U ₂ 3 = Phase U ₃ 4 = Phase U ₁₂ 5 = Phase U ₂₃ 6 = Phase U ₃₁	00
0034	4	r	Status I ₃ : Bit 31..20: Cos(Phi) [0.001] Bit 19..8: Cos(Phi) [0.001] event-triggered Bit 7: Overcurrent (current > measurement range) Bit 6..5: Load type 0 = no information (firmware cannot determine the load type) 1 = capacitive load (current leads voltage) 2 = inductive load (current lags voltage) 3 = purely resistive load Bit 4: U-I phase error (power is positive) Bit 3: Ieff warning (current below 1A) Bit 2..0: Voltage phase selected 0 = Disabled 1 = Phase U ₁ 2 = Phase U ₂ 3 = Phase U ₃ 4 = Phase U ₁₂ 5 = Phase U ₂₃ 6 = Phase U ₃₁	00
0038	4	r	Ieff ₁ [0.1 mA]	00000000
003C	4	r	Ieff ₂ [0.1 mA]	00000000
0040	4	r	Ieff ₃ [0.1 mA]	00000000

0044	4	r	Power 1 [0.01 W]	00000000
0048	4	r	Power 2 [0.01 W]	00000000
004C	4	r	Power 3 [0.01 W]	00000000
Second Device				
0050	4	r	Status I ₄ : Bit 31..20: Cos(Phi) [0.001] Bit 19..8: Cos(Phi) [0.001] event-triggered Bit 7: Overcurrent (current > measurement range) Bit 6..5: Load type 0 = no information (firmware cannot determine the load type) 1 = capacitive load (current leads voltage) 2 = inductive load (current lags voltage) 3 = purely resistive load Bit 4: U-I phase error (power is positive) Bit 3: Ieff warning (current below 1A) Bit 2..0: Voltage phase selected 0 = Disabled 1 = Phase U ₁ 2 = Phase U ₂ 3 = Phase U ₃ 4 = Phase U ₁₂ 5 = Phase U ₂₃ 6 = Phase U ₃₁	00
0054	4	r	Status I ₅ : Bit 31..20: Cos(Phi) [0.001] Bit 19..8: Cos(Phi) [0.001] event-triggered Bit 7: Overcurrent (current > measurement range) Bit 6..5: Load type 0 = no information (firmware cannot determine the load type) 1 = capacitive load (current leads voltage) 2 = inductive load (current lags voltage) 3 = purely resistive load Bit 4: U-I phase error (power is positive) Bit 3: Ieff warning (current below 1A) Bit 2..0: Voltage phase selected 0 = Disabled 1 = Phase U ₁ 2 = Phase U ₂ 3 = Phase U ₃ 4 = Phase U ₁₂ 5 = Phase U ₂₃ 6 = Phase U ₃₁	00
0058	4	r	Status I ₆ : Bit 31..20: Cos(Phi) [0.001] Bit 19..8: Cos(Phi) [0.001] event-triggered Bit 7: Overcurrent (current > measurement range) Bit 6..5: Load type 0 = no information (firmware cannot determine the load type) 1 = capacitive load (current leads voltage) 2 = inductive load (current lags voltage) 3 = purely resistive load Bit 4: U-I phase error (power is positive) Bit 3: Ieff warning (current below 1A)	00

			Bit 2..0: Voltage phase selected 0 = Disabled 1 = Phase U ₁ 2 = Phase U ₂ 3 = Phase U ₃ 4 = Phase U ₁₂ 5 = Phase U ₂₃ 6 = Phase U ₃₁	
005C	4	r	I _{eff4} [0.1 mA]	00000000
0060	4	r	I _{eff5} [0.1 mA]	00000000
0064	4	r	I _{eff6} [0.1 mA]	00000000
0068	4	r	Power 4 [0.01 W]	00000000
006C	4	r	Power 5 [0.01 W]	00000000
0070	4	r	Power 6 [0.01 W]	00000000
Third Device				
0074	4	r	Status I ₇ : Bit 31..20: Cos(Phi) [0.001] Bit 19..8: Cos(Phi) [0.001] event-triggered Bit 7: Overcurrent (current > measurement range) Bit 6..5: Load type 0 = no information (firmware cannot determine the load type) 1 = capacitive load (current leads voltage) 2 = inductive load (current lags voltage) 3 = purely resistive load Bit 4: U-I phase error (power is positive) Bit 3: I _{eff} warning (current below 1A) Bit 2..0: Voltage phase selected 0 = Disabled 1 = Phase U ₁ 2 = Phase U ₂ 3 = Phase U ₃ 4 = Phase U ₁₂ 5 = Phase U ₂₃ 6 = Phase U ₃₁	00
0078	4	r	Status I ₈ : Bit 31..20: Cos(Phi) [0.001] Bit 19..8: Cos(Phi) [0.001] event-triggered Bit 7: Overcurrent (current > measurement range) Bit 6..5: Load type 0 = no information (firmware cannot determine the load type) 1 = capacitive load (current leads voltage) 2 = inductive load (current lags voltage) 3 = purely resistive load Bit 4: U-I phase error (power is positive) Bit 3: I _{eff} warning (current below 1A) Bit 2..0: Voltage phase selected 0 = Disabled 1 = Phase U ₁ 2 = Phase U ₂ 3 = Phase U ₃ 4 = Phase U ₁₂	00

			5 = Phase U ₂₃ 6 = Phase U ₃₁	
007C	4	r	Status I ₉ : Bit 31..20: Cos(Phi) [0.001] Bit 19..8: Cos(Phi) [0.001] event-triggered Bit 7: Overcurrent (current > measurement range) Bit 6..5: Load type 0 = no information (firmware cannot determine the load type) 1 = capacitive load (current leads voltage) 2 = inductive load (current lags voltage) 3 = purely resistive load Bit 4: U-I phase error (power is positive) Bit 3: Ieff warning (current below 1A) Bit 2..0: Voltage phase selected 0 = Disabled 1 = Phase U ₁ 2 = Phase U ₂ 3 = Phase U ₃ 4 = Phase U ₁₂ 5 = Phase U ₂₃ 6 = Phase U ₃₁	00
0080	4	r	Ieff ₇ [0.1 mA]	00000000
0084	4	r	Ieff ₈ [0.1 mA]	00000000
0088	4	r	Ieff ₉ [0.1 mA]	00000000
008C	4	r	Power 7 [0.01 W]	00000000
0090	4	r	Power 8 [0.01 W]	00000000
0094	4	r	Power 9 [0.01 W]	00000000
Fourth Device				
0098	4	r	Status I ₁₀ : Bit 31..20: Cos(Phi) [0.001] Bit 19..8: Cos(Phi) [0.001] event-triggered Bit 7: Overcurrent (current > measurement range) Bit 6..5: Load type 0 = no information (firmware cannot determine the load type) 1 = capacitive load (current leads voltage) 2 = inductive load (current lags voltage) 3 = purely resistive load Bit 4: U-I phase error (power is positive) Bit 3: Ieff warning (current below 1A) Bit 2..0: Voltage phase selected 0 = Disabled 1 = Phase U ₁ 2 = Phase U ₂ 3 = Phase U ₃ 4 = Phase U ₁₂ 5 = Phase U ₂₃ 6 = Phase U ₃₁	00
009C	4	r	Status I ₁₁ : Bit 31..20: Cos(Phi) [0.001] Bit 19..8: Cos(Phi) [0.001] event-triggered Bit 7: Overcurrent (current > measurement range)	00

			Bit 6..5: Load type 0 = no information (firmware cannot determine the load type) 1 = capacitive load (current leads voltage) 2 = inductive load (current lags voltage) 3 = purely resistive load Bit 4: U-I phase error (power is positive) Bit 3: Ieff warning (current below 1A) Bit 2..0: Voltage phase selected 0 = Disabled 1 = Phase U ₁ 2 = Phase U ₂ 3 = Phase U ₃ 4 = Phase U ₁₂ 5 = Phase U ₂₃ 6 = Phase U ₃₁	
00A0	4	r	Status I ₁₂ : Bit 31..20: Cos(Phi) [0.001] Bit 19..8: Cos(Phi) [0.001] event-triggered Bit 7: Overcurrent (current > measurement range) Bit 6..5: Load type 0 = no information (firmware cannot determine the load type) 1 = capacitive load (current leads voltage) 2 = inductive load (current lags voltage) 3 = purely resistive load Bit 4: U-I phase error (power is positive) Bit 3: Ieff warning (current below 1A) Bit 2..0: Voltage phase selected 0 = Disabled 1 = Phase U ₁ 2 = Phase U ₂ 3 = Phase U ₃ 4 = Phase U ₁₂ 5 = Phase U ₂₃ 6 = Phase U ₃₁	00
00A4	4	r	Ieff ₁₀ [0.1 mA]	00000000
00A8	4	r	Ieff ₁₁ [0.1 mA]	00000000
00AC	4	r	Ieff ₁₂ [0.1 mA]	00000000
00B0	4	r	Power 10 [0.01 W]	00000000
00B4	4	r	Power 11 [0.01 W]	00000000
00B8	4	r	Power 12 [0.01 W]	00000000
00BC	340	r	reserved	00
SDO				
Setup Current Channels (I ₁ at 0210, I ₂ at 0214, I ₃ at 0218 ... I ₁₂ at 023C)				
0210	2	r/w	I ₁ setting Bit 15..3: reserved Bit 2..0: Voltage phase selected 0 = Disabled 1 = Phase U ₁ 2 = Phase U ₂ 3 = Phase U ₃ 4 = Phase U ₁₂	0000

			5 = Phase U ₂₃ 6 = Phase U ₃₁	
0212	2	r/w	I1 transformer type [0.1 A]	0000
0214 ... 023F	44	r/w	I2 I ₁₂	
Setup U _{eff} Threshold				
0240	2	r/w	Phase U ₁ U _{eff} threshold for warning [10 mV]	0000
0242	2	r/w	Phase U ₂ U _{eff} threshold for warning [10 mV]	0000
0244	2	r/w	Phase U ₃ U _{eff} threshold for warning [10 mV]	0000
0246 ... 024F	10	r/w	reserved	00...
Firmware-Version				
0250	2	r	CRC	0000
0252	2	r	Length	0000
0254	2	r	Firmware-Version	0000
0256	1	r	reserved	00
0257	1	r	reserved	00
0258 ... 025F	8	r/w	reserved	00...00

13 Maintenance



During maintenance and service, observe the safety guidelines in Chapter 3.

13.1 Service

This product was constructed for low-maintenance operation.

13.2 Repair



When sent for repair, the panel should be transported in the original packaging if possible. Otherwise packaging should be selected that sufficiently protects the product from external mechanical influences, such as cardboard filled with air cushioning.

In the event of a defect/repair, send the panel with a detailed error description to the address listed at the beginning of this document.

14 Disposal



When disposing of the panel, the national electronic scrap regulation must be observed.

The panel cannot be discarded with domestic waste.



15 Hardware Class EE121

EE121 Hardware Class for the EE 121-1 Energy Measuring Module

This hardware class is used to control the EE 121-1 hardware module to measure energy over the S-DIAS bus. More information on the hardware can be found in the module documentation.

```

SDIAS:00, EE121 (EE1211)
  S Class State (ClassState) <-[]-> (_ClassOk)
  S Device ID (DeviceID) <-[]-> (1099)
  S FPGA Version (FPGAVersion) <-[]-> (16#000000F3)
  S Hardware Version (HwVersion) <-[]-> (16#00000100)
  S Serial Number (SerialNo) <-[]-> ("00000000")
  S Retry Counter (RetryCounter) <-[]-> (0)
  O LED Control (LEDControl) <-[]-> (0)
  O Cycle Run (CycleRun) <-[]-> TriggCycleTestClass1.toCycleRun (1)
  O Cycle Start (CycleStart) <-[]-> TriggCycleTestClass1.toCycleStart (0)
+ EE121_GeneralData:00, EE121 General Data (EE121GeneralData1)
+ EE121_Voltage:00, EE121 Voltage Channel (EE121VoltageChannel1)
+ EE121_Voltage:01, EE121 Voltage Channel (EE121VoltageChannel2)
+ EE121_Voltage:02, EE121 Voltage Channel (EE121VoltageChannel3)
+ EE121_Voltage:03, EE121 Voltage Channel (EE121VoltageChannelU12)
+ EE121_Voltage:04, EE121 Voltage Channel (EE121VoltageChannelU23)
+ EE121_Voltage:05, EE121 Voltage Channel (EE121VoltageChannelU31)
+ EE121_Current:00, EE121 Current Channel (EE121CurrentChannel1)
+ EE121_Current:01, EE121 Current Channel (EE121CurrentChannel2)
+ EE121_Current:02, EE121 Current Channel (EE121CurrentChannel3)
+ EE121_Current:03, EE121 Current Channel (EE121CurrentChannel4)
+ EE121_Current:04, EE121 Current Channel (EE121CurrentChannel5)
+ EE121_Current:05, EE121 Current Channel (EE121CurrentChannel6)
+ EE121_Current:06, EE121 Current Channel (EE121CurrentChannel7)
+ EE121_Current:07, EE121 Current Channel (EE121CurrentChannel8)
+ EE121_Current:08, EE121 Current Channel (EE121CurrentChannel9)
+ EE121_Current:09, EE121 Current Channel (EE121CurrentChannel10)
+ EE121_Current:10, EE121 Current Channel (EE121CurrentChannel11)
+ EE121_Current:11, EE121 Current Channel (EE121CurrentChannel12)
+ EE121_Oscilloscope:00, EE121 Oscilloscope (EE121Oscilloscope1)

```

Properties	
Object of class EE121	EE1211
Place	0
Place(s) for EE121_CurrentChannel (def. 12)	12
Place(s) for EE121_GeneralDataChannel (def. 1)	1
Place(s) for EE121_OscilloscopeChannel (def. 1)	1
Place(s) for EE121_VoltageChannel (def. 6)	6
Required	Module is not required
PDO Data Cycles	every 4 cycles
Compatibility Mode	DEE021 resolution
New Data Available	
Place number of highest Current Channel	12
⊕ Settings for 'EE1211'	
⊕ Voltage 5000 [mV]	
⊕ Voltage 24000 [mV]	

15.1 General

Class State	State	This server shows the actual status of the hardware class.								
Device ID	State	This server shows the device ID of the hardware module.								
FPGA Version	State	FPGA version of the module in 16#XY (e.g. 16#10 = version 1.0).								
Hardware Version	State	Hardware version of the module in format 16#XXYY (e.g. 16#0120 = version 1.20)								
Serial Number	State	The serial number of the hardware module is shown in this server.								
Retry Counter	State	This server increments when a transfer fails.								
LED Control	Output	<p>With this server, the application LED of the S-DIAS module can be activated to find the module in the network more quickly.</p> <table border="1"> <tr> <td>0</td> <td>LED off</td> </tr> <tr> <td>1</td> <td>LED on</td> </tr> <tr> <td>2</td> <td>Slow blinking</td> </tr> <tr> <td>3</td> <td>Fast blinking</td> </tr> </table>	0	LED off	1	LED on	2	Slow blinking	3	Fast blinking
0	LED off									
1	LED on									
2	Slow blinking									
3	Fast blinking									
Firmware Version	State	Here, the firmware version used in the module is displayed in 16#XXYY format (e.g. 16#0120 = Version 1.20)								
Required	Property	This client is activated by default, i.e. this S-DIAS hardware module at this position is absolutely necessary for the system and may under no circumstances be missing, disconnected or deliver an error, otherwise, the entire hardware is switched off. If the hardware module is missing, it returns an error or if it is removed, this triggers an S-DIAS error. If this client is initialized with 0, this hardware module is not mandatory at the position. This means that it can be removed at any time. However, the components to be identified as "not required" should be selected with regard to the safety of the system.								

15.2 Module-Specific

PDO Data Cycles	Property	<p>Used to define the data exchange mode (time in which the data is updated).</p> <table border="1" style="width: 100%; border-collapse: collapse;"> <tr><td style="text-align: center;">0</td><td>Default, every 64th cycle (max PDO size 8 bytes)</td></tr> <tr><td style="text-align: center;">1</td><td>Every 32nd cycle (max PDO size 16 bytes)</td></tr> <tr><td style="text-align: center;">2</td><td>Every 16th cycle (max PDO size 32 bytes)</td></tr> <tr><td style="text-align: center;">3</td><td>Every 8th cycle (max PDO size 64 bytes)</td></tr> <tr><td style="text-align: center;">4</td><td>Every 4th cycle (max PDO size 128 bytes)</td></tr> </table> <p>The maximum PDO since is required when current channel 12 is placed. Duration of one cycle is: with local S-DIAS the "CycleTime" of the SdiasPLCand after VARAN the "VaranManagerTime" of the VaranManager. as initial value</p>	0	Default, every 64 th cycle (max PDO size 8 bytes)	1	Every 32 nd cycle (max PDO size 16 bytes)	2	Every 16 th cycle (max PDO size 32 bytes)	3	Every 8 th cycle (max PDO size 64 bytes)	4	Every 4 th cycle (max PDO size 128 bytes)
	0	Default, every 64 th cycle (max PDO size 8 bytes)										
	1	Every 32 nd cycle (max PDO size 16 bytes)										
	2	Every 16 th cycle (max PDO size 32 bytes)										
	3	Every 8 th cycle (max PDO size 64 bytes)										
	4	Every 4 th cycle (max PDO size 128 bytes)										
Property	<p>The compatibility mode is used to provide the values in the same unit as the DEE021.</p> <table border="1" style="width: 100%; border-collapse: collapse;"> <tr><td style="text-align: center;">0</td><td>High resolution</td></tr> <tr><td style="text-align: center;">1</td><td>Resolution same as DEE021</td></tr> </table> <p>as initial value</p>	0	High resolution	1	Resolution same as DEE021							
0	High resolution											
1	Resolution same as DEE021											
Property	<p>If new data is available (see PDO Data Cycles), the "Write" method is called is called from the server connected to the client.</p>											
Output	<p>The server is filled with 1 so that the data for the "triggered values" can be recorded as soon as the value 1 is written to the CycleStart server. By writing 0, the process is stopped.</p>											
Output	<p>If the value 1 is written to the server, the actual triggered data transferred from the EE 121-1 to the class. 1 must first be written to the "CycleRun" server, so that this function can be used. The server is automatically reset after 100 ms. If the server is newly written to before the time has elapsed, it will have no effect.</p>											
State Downlink	<p>This server shows the actual status of the class:</p> <table border="1" style="width: 100%; border-collapse: collapse;"> <tr><td style="text-align: center;">0</td><td>IDLE: The class is ready for asynchronous data transfer.</td></tr> <tr><td style="text-align: center;">1</td><td>BUSY: The class is currently performing an asynchronous data transfer.</td></tr> <tr><td style="text-align: center;">-1</td><td>ERROR: An error has occurred during the asynchronous data transfer.</td></tr> </table> <p>It also is used to connect with the EE121VoltageChannel, EE121CurrentChannel, EE121GeneralData and the EE121Oscilloscope subclass.</p>	0	IDLE: The class is ready for asynchronous data transfer.	1	BUSY: The class is currently performing an asynchronous data transfer.	-1	ERROR: An error has occurred during the asynchronous data transfer.					
0	IDLE: The class is ready for asynchronous data transfer.											
1	BUSY: The class is currently performing an asynchronous data transfer.											
-1	ERROR: An error has occurred during the asynchronous data transfer.											
Compatibility Mode												
New Data Available												
Cycle Run												
Cycle Start												
EE Conn												

15.3 Internal Properties

15.3.1 Using the Trigger Function

By writing 1 to the "CycleRun" server, the recording of the data required for triggered values is started. Recording is stopped when 0 is written to the server. If the "CycleRun" server is set to 1, writing 1 to the "CycleStart" server sets the trigger and the "triggered" data is written to the appropriate servers. The server is automatically reset after 100 ms and only then can a new trigger be set.



- The method for reading the time stamps from the EE121VoltageChannel class must be called from Realtime.
- The EE 121-1 module requires the SDIAS Manager Protocol version 1.2.0 to recognize the timestamp function for the zero crossing. If this version is not available, the timestamp mod will not work. This version can be checked in the hardware class SdiasPLC, VI021, VI022 in the "ManagerProtocolVersion". If this server is not available, the hardware class must be updated. If no protocol version is shown in the server, the CPU operating system must be updated. If a protocol version lower than 1.2.0 is displayed, the FPGA and Firmware of the CPU or VI 021, VI 022 must be updated.

15.4 Global Methods

15.4.1 OsciGetStreamingData

This method can be called via the ClassState server.

If streaming mode is activated on the EE121Oscilloscope class, the streaming data can be retrieved here.

Transfer parameters	Type	Description												
usChannelNr	USINT	Selects the oscilloscope channel from which the values should be read Permissible values: 1-4												
uiBufferSize	UINT	Indicates the buffer size in bytes, into which the values should be copied. Permissible values: 4 to 65532 bytes = 1 to 16383 values												
puiCopySize	^UINT	Returns the number of copied values in bytes. Permissible values: 4 to 65532 = 1 to 16383 values												
pDataCounter	^UDINT	Initialized with NIL. If a valid pointer is sent, this variable counts up when new data is available.												
Return Parameters	Type	Description												
retval	DINT	Return value of the function. <table border="1" data-bbox="532 774 991 981"> <tbody> <tr> <td>1</td> <td>no data in the buffer</td> </tr> <tr> <td>0</td> <td>OK – data are copied</td> </tr> <tr> <td>-1</td> <td>Channel is not active.</td> </tr> <tr> <td>-2</td> <td>Channel number is invalid</td> </tr> <tr> <td>-3</td> <td>Specified buffer size is too small (minimum 4 bytes)</td> </tr> <tr> <td>-4</td> <td>Osc streaming mode is not activated</td> </tr> </tbody> </table>	1	no data in the buffer	0	OK – data are copied	-1	Channel is not active.	-2	Channel number is invalid	-3	Specified buffer size is too small (minimum 4 bytes)	-4	Osc streaming mode is not activated
1	no data in the buffer													
0	OK – data are copied													
-1	Channel is not active.													
-2	Channel number is invalid													
-3	Specified buffer size is too small (minimum 4 bytes)													
-4	Osc streaming mode is not activated													

15.4.2 GetHWTimeStamp

The timestamps in the EE121VoltageChannel class refer to the hardware time stamp. This is returned by the “GetHWTimeStamp” method (2-byte time, resolution μs). This is based on the start of each real-time cycle.

Transfer parameters	Type	Description
none		
Return Parameters	Type	Description
HWTimeStamp	UINT	Hardware time stamp in μs . This is based on the start of each real-time cycle. If the time stamp cannot be determined, the constant 0 is returned.

Documentation Changes

Change date	Affected page(s)	Chapter	Note
09.03.2023	21	7.2 Applicable Connectors	Changed temperature rating of the cable to minimum 80 °C